

Cast Steel Swing Check Valve

Figures 175
175½

CRANE®

Class 600 • Bolted Cap

Material of Construction*

Description	Material
Body	WCB
Cap	WCB
Seat Ring	Hardfaced
Disc	13% CR Overlay
Hinge	WCB
Pins, Hinge	410 SS
Disc Washer	Steel
Cap Screw	A307 Gr. B
Cap Gasket	Ring Type Joint
Cap Studs	A193 Gr. B7
Cap Nuts	A194 Gr. 2H
I.D. Tags	SS
I.D. Pins	Steel

Figure 175

Flanged

Figure 175½

Butt Weld

Size Range:

2 through 12 inches
(50 - 300 mm)

Pressure Temperature Rating

Carbon Steel
ASTM A216 Grade WCB
1480 psi @ -20°F to 100°F
(102 bar @ -28°C to 37°C)

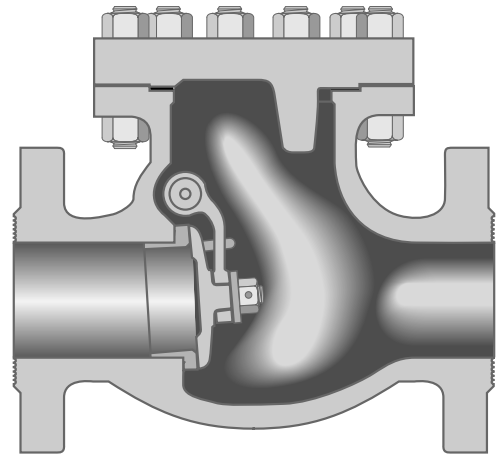

NOTE:

*Standard construction: WCB-Trim 8, other options are available.

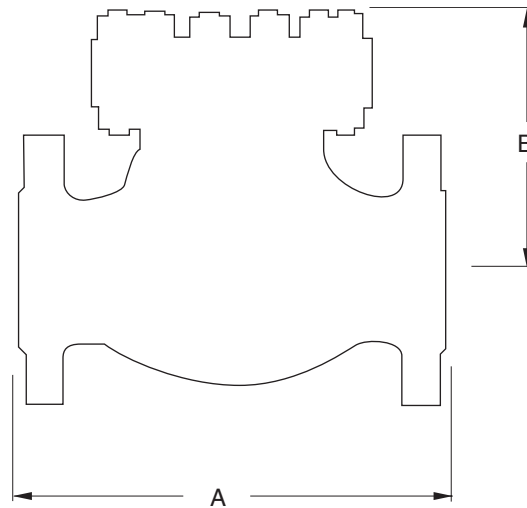

Industry Standards

Steel Valves	ASME B16.34
Face-to-Face/End-to-End	ASME B16.10
Flange Dimensions	ASME B16.5
Weld End	ASME B.16.25
Testing	API 598

Dimensions and Weights

Inches (millimeters) - pounds (kilograms)

Valves	2 (50)	2 ½ (65)	3 (80)	4 (100)	6 (150)	8 (200)	10 (250)	12 (300)
A	11.50 (292)	13.00 (330)	14.00 (356)	17.00 (431)	22.00 (558)	26.00 (660)	31.00 (787)	33.00 (838)
B (Open)	7 (178)	8 (203)	9 (229)	11 (279)	13 (330)	16 (406)	19 (482)	21 (533)
Wt. (175)	115 (52)	145 (65)	161 (73)	284 (128)	500 (226)	1025 (464)	1400 (635)	1950 (884)
Wt. (175½)	100 (45)	125 (56)	154 (69)	250 (113)	450 (204)	850 (385)	1300 (589)	1800 (816)