

Class 300 • Bolted Cap

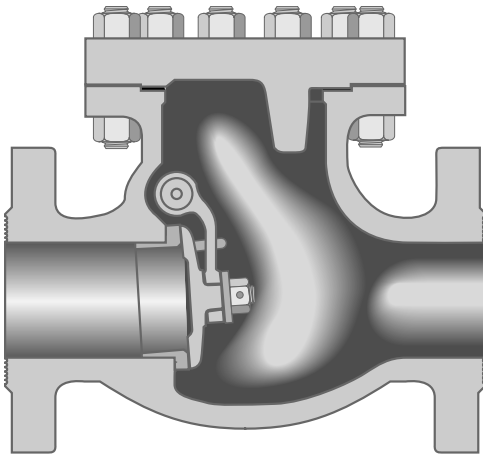

Figure 159

Flanged

Figure 159½

Butt Weld

Size Range:

2 through 24 inches
(50 - 600 mm)

Pressure Temperature Rating

Carbon Steel
ASTM A216 Grade WCB
740 psi @ -20°F to 100°F
(51 bar @ -28°C to 37°C)

Material of Construction*

Description	Material
Body	WCB
Cap	WCB
Seat Ring	Hardfaced
Disc	13% CR Overlay
Hinge	WCB
Pins, Hinge	410 SS
Disc Washer	Steel
Cap Screw	A307 Gr. B
Cap Gasket	Stainless Steel spiral wound Graphite
Cap Studs	A193 Gr. B7
Cap Nuts	A194 Gr. 2H
I.D. Tags	SS
I.D. Pins	Steel

NOTE:

*Standard construction: WCB-Trim 8, other options are available.

Industry Standards

Steel Valves	ASME B16.34
Face-to-Face/End-to-End	ASME B16.10
Flange Dimensions	ASME B16.5
Weld End	ASME B.16.25
Testing	API 598

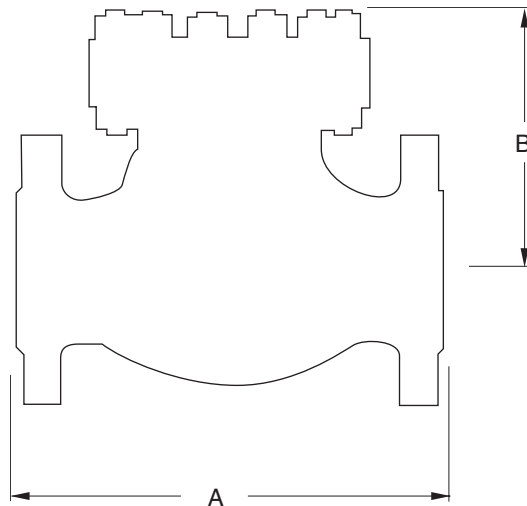

Dimensions and Weights

Inches (millimeters) - pounds (kilograms)

Valves	2 (50)	2½ (65)	3 (80)	4 (100)	6 (150)	8 (200)	10 (250)	12 (300)	14 (350)	16 (400)	18 (450)	20 (500)	24 (600)
A	10.50 (266)	11.50 (292)	12.50 (317)	14.00 (356)	17.50 (444)	21.00 (533)	24.50 (622)	28.00 (711)	33.00 (838)	34.00 (863)	38.50 (977)	40.00 (1016)	53.00 (1346)
B (Open)	7 (178)	8 (203)	8 (203)	9 (229)	11 (279)	14 (355)	16 (406)	19 (482)	19 (482)	22 (558)	23 (584)	25 (635)	30 (762)
Wt.	46 (159)	66 (20)	86 (29)	154 (69)	276 (125)	460 (208)	675 (306)	860 (390)	1500 (680)	1850 (839)	2250 (1020)	2900 (1315)	4350 (1973)
Wt. (159½)	33 (14)	49 (22)	86 (39)	97 (43)	276 (125)	460 (208)	677 (307)	992 (449)	1500 (680)	1850 (839)	2250 (1020)	2900 (1315)	4350 (1973)