

Class 1500 • Bolted Cap

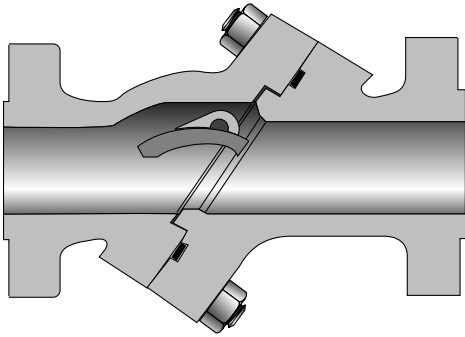

Figure 1523

Flanged

Figure 1523½

Butt Weld

Size Range:

2 through 10 inches
(50 - 250 mm)

Pressure Temp. Rating

Carbon Steel
ASTM A216 Grade WCB
3705 psi @ -20°F to 100°F
(256 bar @ -28°C to 37°C)

Material of Construction*

Description	Material
Inlet Body	ASTM A216 WCB
Outlet Body	ASTM A216 WCB
Disc	13% CR Overlay
Pivot Pin	SS
Body Gasket	Stainless Steel spiral wound Graphite
Body Studs	ASTM A193 B7
Body Nuts	ASTM A194 2H
Bearing Cap	Carbon Steel
Bearing Cap Gaskets	Soft Steel
Bearing Cap Studs	ASTM A193 B7
Bearing Cap Nuts	ASTM A194 2H
Dowel Pins	Carbon Steel

NOTE:

*Standard construction: WCB-Trim 8, other options are available.

Industry Standards

All materials comply with ASME B16.34

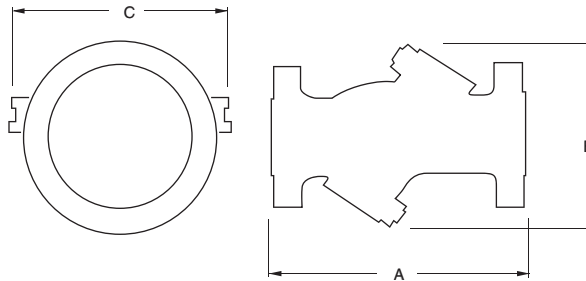

Dimensions and Weights

Inches (millimeters) - pounds (kilograms)

Valves	2 (50)	2½ (65)	3 (80)	4 (100)	6 (150)	8 (200)	10 (250)
A	14.50 (368)	16.50 (419)	18.50 (469)	21.50 (546)	27.75 (704)	32.75 (831)	39.00 (990)
B	12 (304)	12 (304)	12 (304)	15 (381)	19 (482)	22 (558)	29 (736)
C	17 (431)	17 (431)	17 (431)	21 (533)	24 (609)	30 (762)	38 (965)
Wt. (1523)	177 (80)	273 (123)	438 (198)	604 (273)	1050 (476)	1770 (802)	2415 (1095)
Wt. (1523½)	107 (48)	164 (74)	286 (129)	464 (210)	760 (344)	1440 (653)	1610 (730)