

## Class 150 • Bolted Cap

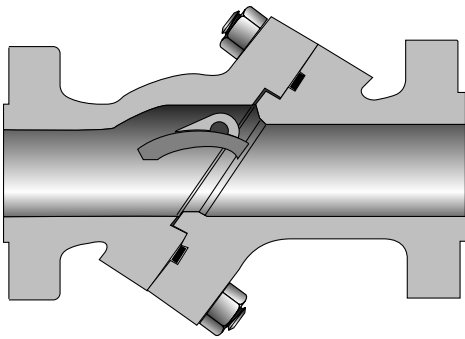

**Figure 123**

Flanged

**Figure 123½**

Butt Weld

**Size Range:**

2 through 36 inches  
(50 - 900 mm)

**Pressure Temp. Rating**

Carbon Steel  
ASTM A216 Grade WCB  
285 psi @ -20°F to 100°F  
(20 bar @ -28°C to 37°C)

**Material of Construction\***

Description	Material
Inlet Body	ASTM A216 WCB
Outlet Body	ASTM A216 WCB
Disc	13% CR Overlay
Pivot Pin	SS
Body Gasket	Stainless Steel spiral wound Graphite
Body Studs	ASTM A193 B7
Body Nuts	ASTM A194 2H
Bearing Cap	Carbon Steel
Bearing Cap Gaskets	Soft Steel
Bearing Cap Studs	ASTM A193 B7
Bearing Cap Nuts	ASTM A194 2H
Dowel Pins	Carbon Steel

**NOTE:**

\*Standard construction: WCB-Trim 8, other options are available.

**Industry Standards**

All materials comply with ASME B16.34

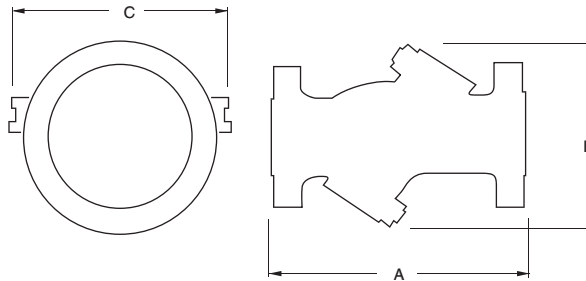

**Dimensions and Weights**

Inches (millimeters) - pounds (kilograms)

Valves	2 (50)	2 ½ (65)	3 (80)	4 (100)	5 (125)	8 (200)	10 (250)	12 (300)	14 (350)	16 (400)	18 (450)	20 (500)	24 (600)	30 (750)	36 (900)
A	8.00 (203)	8.50 (216)	9.50 (241)	11.50 (292)	13.00 (330)	19.50 (495)	24.50 (622)	27.50 (698)	31.00 (787)	30.00 (762)	33.00 (838)	32.50 (825)	38.00 (965)	49.50 (1257)	59.50 (1511)
B	7 (177)	9 (229)	9 (229)	10 (254)	11 (279)	16 (406)	19 (482)	21 (533)	22 (558)	25 (635)	28 (711)	31 (787)	36 (914)	44 (1117)	50 (1270)
C	8 (203)	9 (229)	9 (229)	13 (330)	16 (406)	21 (533)	25 (635)	28 (711)	29 (736)	34 (863)	36 (914)	39 (990)	45 (1143)	54 (1371)	60 (1524)
Wt. (123)	38 (17)	51 (23)	59 (26)	102 (46)	139 (63)	293 (132)	488 (221)	690 (312)	823 (373)	1070 (485)	1435 (650)	1825 (827)	2887 (1309)	4790 (2172)	6795 (3082)
Wt. (123½)	22 (9)	38 (17)	42 (19)	75 (34)	108 (48)	240 (108)	400 (181)	570 (258)	690 (312)	885 (401)	1213 (550)	1760 (798)	2265 (1027)	4025 (1825)	5755 (2610)