

**CRANE**

®



## Resilient Seated Butterfly Valves

**CRANE**

®

THE VALVE EXPERTS



Crane has been a market leader in quarter-turn valves for more than 40 years, and we have earned a reputation as a supplier of superior valves at competitive prices. Our goal is to exceed industry requirements and customer expectations.

We are committed to offering products that meet a wide range of applications and requirements. We continually improve our product line by introducing new products and enhancing existing designs, providing our customers with the best products on the market.

Our complete line of resilient seated butterfly valves provides you with the reliability you need, backed by the guarantee that comes with using valves designed and produced in company-owned manufacturing facilities.

## Crane Resilient Seated Butterfly Valves Product Features

- Qualified for both gaseous and liquid service
- Positive shut-off bi-directionally
- Phenolic backed cartridge seat
- PTFE bushing standard
- Locking handle standard (2"-12")
- End of line service on lug style standard
- Ease of automation
- Field repairable (2"-24")
- Complete size range: 2 through 48 inches

## Typical Applications

- HVAC
- Chemical/  
Petrochemical  
Processing
- Food and  
Beverage
- Power and Utilities

NOTE: In keeping with our policy of continuing improvement, we reserve the right to institute changes in design, material, dimensions, or specifications without notice and without incurring any obligation to make such changes and modifications on product previously or subsequently sold.

Crane Series 21 (wafer) and 23 (lug) valves utilize the same proven design features as our Series 42 and 44 valves but are rated to 285 psi. These design features include a phenolic-backed cartridge seat, precision profile disc, one-piece shaft, and four shaft support bearings. Series 21 and 23 heavy-duty butterfly valves are designed for the hostile operating conditions and high pressures encountered in many piping systems today. With the fully-lined body isolated from the flow stream, the use of expensive alloys is limited to the disc and taper pins.

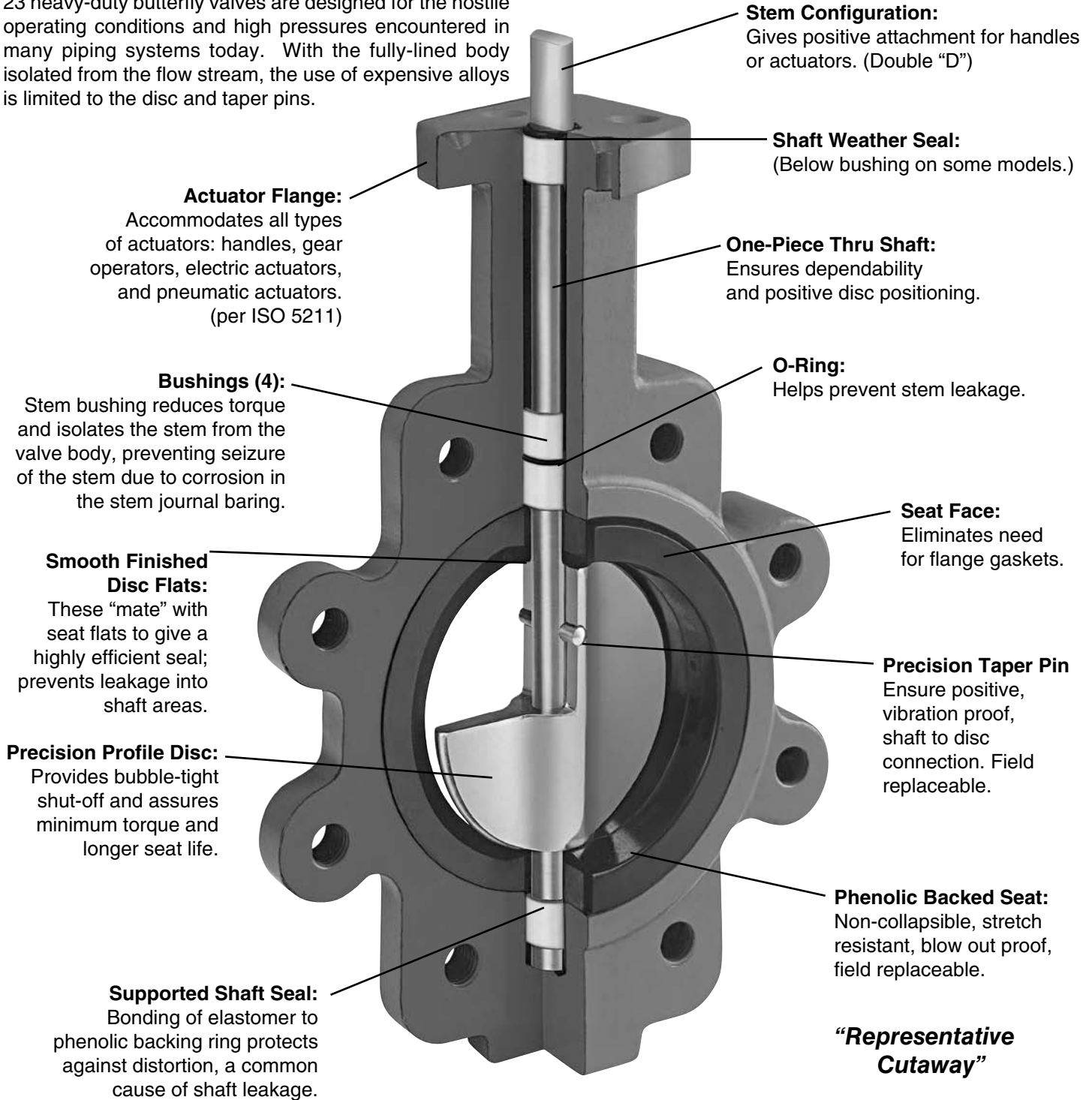

- Available in sizes 2" to 24".
- Pressure Rating: 285 psi at 100°F. Pressure/Temperature rating above 100°F corresponds to ASME B16.5 Class 150 for steel flanges.
- Available in Wafer (21) or Lug (23) style body.
- Wafer body features four alignment holes.
- Available in ASME Class 300 Lug Body bolt pattern 2" to 12" (Series 21/23 only).
- Ideal for on-off or throttling services.
- Available with handles (2" to 6"), manual gear operators, electric actuators and pneumatic actuators (2" to 24").
- Refer to Crane automation bulletin for details of pneumatic and electric actuators.

- Compatible with ASME B16.1 Class 125 (Iron) and ASME B16.5 Class 150 (Steel) flanges or optional Class 300 (Steel) Lug only.
- Bi-directional dead-end capability to 200 psi (2" to 12") and 150 psi (14" to 24") is an available option.
- Valves 14" and larger are rated at a maximum 150 psi when a companion flange is not used in dead end service.
- For bolting information, consult the Crane Butterfly Installation and Maintenance Manual.
- Vacuum Service Rating: zero leakage at 24" of mercury.
- Commercial cleaning available for non-silicone and O<sub>2</sub>.
- Type approval certification from ABS for Marine applications (2" to 24").
- PED Certification available for sizes 2" to 24".

### Valve Seating Torques (In-Lbs.)

Valve Size	Standard Disc Differential Pressure				
	50 PSI	100 PSI	150 PSI	200 PSI	285 PSI
2"	136	142	148	154	164
2 1/2"	152	160	168	176	189
3"	224	229	234	239	247
4"	380	392	404	416	436
5"	451	477	503	529	572
6"	875	946	1016	1087	1206
8"	1476	1559	1642	1726	1867
10"	2451	2613	2775	2937	3213
12"	3900	4111	4323	4534	4893
14"	5189	5467	5744	6022	6494
16"	10,985	11,569	12,154	12,738	13,732
18"	13,946	14,688	15,431	16,173	17,434
20"	14,695	15,478	16,260	17,043	18,373
24"	29,738	31,321	32,903	34,486	37,176

All torques shown on the chart were derived from test data using water at 60°F. For torques using dry gases, multiply these numbers by 2.0. For torques involving other media, please consult the factory.

There is no safety factor included in the numbers shown on this chart. For actuator sizing, Crane recommends that these values be multiplied by 1.5 for single valve applications, or 2.0 for 3-way ("tee") applications.

For PTFE seats multiply the numbers shown on this chart by 2.0.

Under certain conditions, hydrodynamic torque can meet or exceed seating and unseating torques. When designing valve systems, hydrodynamic torque must be considered to help assure correct selection for the application.

### Seat Temperature Ratings

Material	Temperature Rating °F
Buna-N	+10 to 180
EPDM (2"-16")	-30 to 275
EPDM (18"-24")	-30 to 225
Abrasive Resistant Buna-N	+10 to 180
Neoprene	+20 to 200
Hypalon	0 to 275
Viton	+10 to 275
High Temperature Viton	+10 to 400

Although elastomers have an effective operating temperature range, when used in valves, these ranges may have to be modified. The temperature ranges shown in the table have been adjusted accordingly.

**For Low Temperature:** While the seat materials selected for use in Crane butterfly valves are capable of withstanding lower temperatures without damage, the durometer of the elastomer is changed. This "hardening" of the seat may increase the operating torque beyond the structural limits of the stem and/or the disc to stem configuration.

**For High Temperature:** When using High Temperature Viton, the operating pressure of the valve is reduced above 275°F.

**Field Replacement:** Replacing seats in sizes 12" - 20" is difficult and requires factory service. Sizes 24" and above cannot be field replaced.

### C<sub>v</sub> Values – Valve Sizing Coefficients (US-GPM @ 1ΔP)

Size	10°	20°	30°	40°	50°	60°	70°	80°	90°
2"	0.06	3	7	15	27	44	70	105	115
2 1/2"	0.10	6	12	25	45	75	119	178	196
3"	0.20	9	18	39	70	116	183	275	302
4"	0.30	17	36	78	139	230	364	546	600
5"	0.50	29	61	133	237	392	620	930	1022
6"	0.80	34	94	153	257	422	706	1154	1320
8"	2	56	154	251	422	693	1158	1892	2165
10"	3	87	238	385	654	1073	1794	2931	3353
12"	4	153	417	681	1145	1879	3142	5132	5827
14"	6	183	500	816	1372	2252	3765	6150	7037
16"	8	271	740	1208	2031	3333	5573	9104	10,416
18"	11	318	867	1417	2382	3909	6535	10,676	12,215
20"	14	415	1133	1851	3112	5107	8538	13,948	15,959
24"	22	543	1482	2421	4069	6678	11,165	18,240	20,869

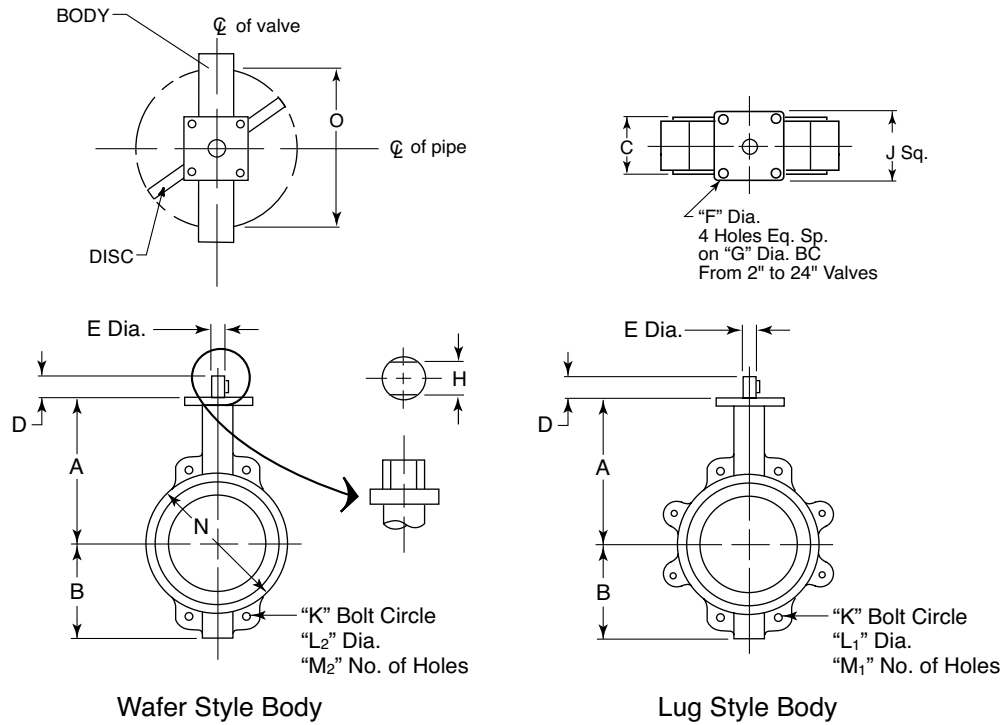

## Dimensions and Weights

For installation and maintenance instructions, please refer to the IOM manual available at [www.cranevalve.com](http://www.cranevalve.com)

Valve Size		A	B	C	D	E	F	G	H	J	K	300# K	L <sub>1</sub>	300# L <sub>1</sub>	L <sub>2</sub>	M <sub>1</sub>	300# M <sub>1</sub>	M <sub>2</sub>	WAFER	LUG	300# LUG	O
2"	in.	6 3/8	3 1/4	1 3/4	1 1/4	1/2	3/8	2.76	0.39	2 3/4	4 3/4	5	5/8-11	5/8-11	1 1/8	4	8	4	6 lbs.	9 lbs.	9 lbs.	1.26
50	mm	161.93	82.55	44.45	31.75	12.70	9.53	70	10	69.85	120.65	127.00			17.46				2.72 kg	4.08 kg	4.08 kg	32.0
2 1/2"	in.	6 7/8	3 3/4	1 7/8	1 1/4	1/2	3/8	2.76	0.39	2 3/4	5 1/2	5 1/2	5/8-11	5/8-11	1 1/8	4	8	4	7 lbs.	13 lbs.	13 lbs.	1.83
65	mm	174.63	95.25	47.63	31.75	12.70	9.53	70	10	69.85	139.70	149.23			17.46				3.18 kg	5.90 kg	5.90 kg	46.5
3"	in.	7 1/8	4	1 7/8	1 1/4	1/2	3/8	2.76	0.39	2 3/4	6	6 3/8	5/8-11	5/8-11	1 1/8	4	8	4	10 lbs.	14 lbs.	14 lbs.	2.54
80	mm	180.98	101.60	47.63	31.75	12.70	9.53	70	10	69.85	152.40	168.28			17.46				4.54 kg	6.35 kg	6.35 kg	64.5
4"	in.	7 7/8	4 7/8	2 1/4	1 1/4	5/8	3/8	2.76	0.47	2 3/4	7 1/2	7 7/8	5/8-11	5/8-11	1 1/8	8	8	4	13 lbs.	19 lbs.	24 lbs.	3.54
100	mm	200.03	123.83	53.98	31.75	15.88	9.53	70	12	69.85	190.50	200.03			17.46				5.90 kg	8.62 kg	10.89 kg	89.9
5"	in.	8 3/8	5 3/8	2 1/4	1 1/4	3/4	3/8	2.76	0.55	2 3/4	8 1/2	9 1/4	3/4-10	3/4-10	1 3/8	8	8	4	18 lbs.	22 lbs.	29 lbs.	4.36
125	mm	212.73	136.53	57.15	31.75	19.05	9.53	70	14	69.85	215.90	234.95			20.64				8.16 kg	9.98 kg	13.15 kg	110.7
6"	in.	8 7/8	5 7/8	2 1/4	1 1/4	3/4	3/8	2.76	0.55	2 3/4	9 1/2	10 5/8	3/4-10	3/4-10	1 3/8	8	12	4	21 lbs.	31 lbs.	38 lbs.	5.74
150	mm	225.43	149.23	57.15	31.75	19.05	9.53	70	17	69.85	241.30	269.88			20.64				9.53 kg	14.06 kg	17.24 kg	145.8
8"	in.	10 1/4	7 3/4	2 1/2	1 3/4	7/8	7/16	4.02	0.67	3 3/4	11 3/4	13	3/4-10	7/8-9	1 3/8	8	12	4	34 lbs.	49 lbs.	67 lbs.	7.63
200	mm	260.35	196.85	63.50	44.45	22.23	11.11	102	17	95.33	298.45	330.20			20.64				15.42 kg	22.23 kg	30.39 kg	193.8
10"	in.	11 1/2	8 1/4	2 3/4	1 3/4	1 1/2	7/16	4.02	0.87	3 3/4	14 1/4	15 1/4	7/8-9	1-8	1 3/8	12	16	4	45 lbs.	62 lbs.	100 lbs.	9.54
250	mm	292.10	209.55	69.85	44.45	28.58	11.11	102	22	95.33	361.95	387.35			23.81				20.41 kg	28.12 kg	45.36 kg	242.3
12"	in.	13 1/4	9 3/4	3 3/8	1 3/4	1 1/4	7/16	4.02	0.95	3 3/4	17	17 3/4	7/8-9	1 1/2-7	1 3/8	12	16	4	74 lbs.	105 lbs.	144 lbs.	11.5
300	mm	336.55	247.65	79.38	44.45	31.75	11.11	102	24	95.33	431.80	450.85			23.81				33.57 kg	47.63 kg	65.32 kg	292.1
14"	in.	14 1/2	11	3 1/8	1 3/4	1 1/4	7/16	4.02	0.95	3 3/4	18 3/4	-	1-8	-	1 3/8	12	-	4	109 lbs.	178 lbs.	-	12.81
350	mm	368.30	279.40	79.38	44.45	31.75	11.11	102	24	95.33	476.25	-			26.99				49.44 kg	80.74 kg	-	325.4
16"	in.	15 3/4	12	3 1/2	2	1 1/2	7/16	6.50	1.06	6 1/2	21 1/4	-	1-8	-	1 3/8	16	-	4	135 lbs.	224 lbs.	-	15
400	mm	400.05	304.80	88.90	50.80	33.34	22.23	165	27	165.10	539.75	-			26.99				61.24 kg	101.60 kg	-	381.0
18"	in.	16 5/8	15	4 1/8	2	1 5/8	7/16	6.50	1.26	6 1/2	22 3/4	-	1 1/2-7	-	1 3/8	16	-	4	190 lbs.	265 lbs.	-	16.87
450	mm	422.28	381.00	107.95	50.80	41.28	22.23	165	32	165.10	577.85	-			30.16				86.18 kg	120.20 kg	-	428.5
20"	in.	18 7/8	15	5 1/4	2 1/2	1 5/8	7/16	6.50	1.26	6 1/2	25	-	1 1/2-7	-	3/4-20	20	-	4	316 lbs.	455 lbs.	-	18.69
500	mm	479.43	381.00	133.35	63.50	41.28	22.23	165	32	165.10	635.00	-			25.00				143.34 kg	206.38 kg	-	474.7
24"	in.	22 1/2	18	6 1/8	2 3/4	3	7/16	6.50	2.36	6 1/2	29 1/2	-	1 1/2-7	-	1 3/4-20	20	-	4	506 lbs.	702 lbs.	-	22.57
600	mm	561.98	457.20	155.58	69.85	76.20	22.23	165	60	165.10	749.30	-			28.18				229.52 kg	318.42 kg	-	573.3

NOTE: 20" Wafer: L<sub>2</sub> dia. Hole is Tapped w/1-1/8-7 on Each Side

24" Wafer: L<sub>2</sub> dia. Hole is Tapped w/1-1/4-7 on Each Side

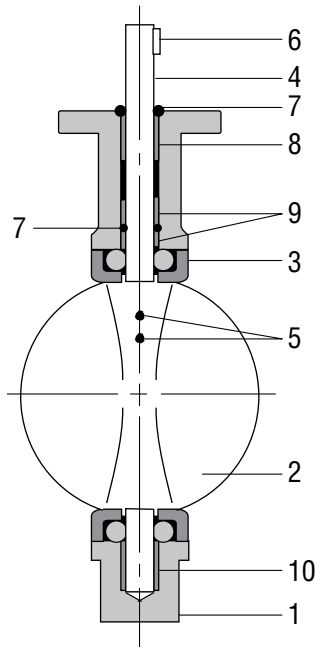

**Bill of Materials (21 / 23)**

Item	Description	Materials	Optional Materials
1	Body	Ductile Iron	No Options Available
2	Disc	Ductile Iron <sup>†</sup>	Aluminum Bronze, 316 Stainless Steel, Monel
3	Seat	Buna-N or EPDM	Neoprene, Hypalon, Abrasive Resistant Buna-N, Low Temperature Viton, High Temperature Viton
4	Shaft	416 Stainless Steel	2"-12": 17-4 PH, Monel
5	Taper Pin	300 Series Stainless	Monel
6	Key	Carbon Steel	No Option Available
7	O-Ring	Buna-N	No Option Available
8	Bushing	PTFE	No Option Available
9	Bushing	PTFE	No Option Available
10	Bushing	PTFE	No Option Available

<sup>†</sup>ENP plated for 2" - 12" valves

Crane Series 52 / 54 and 62 / 64 valves utilize the same proven design features as our Series 21 and 23 valves but are supplied with either a carbon steel (52 / 54) or 316 stainless steel (62 / 64) body. Both are rated to 285 psi. These design features include a phenolic-backed cartridge seat, precision profile disc, one-piece shaft, and four shaft support bearings. Series 52 / 54 and 62 / 64 heavy-duty butterfly valves are designed for the harsh operating conditions and high pressures encountered in many piping systems today.

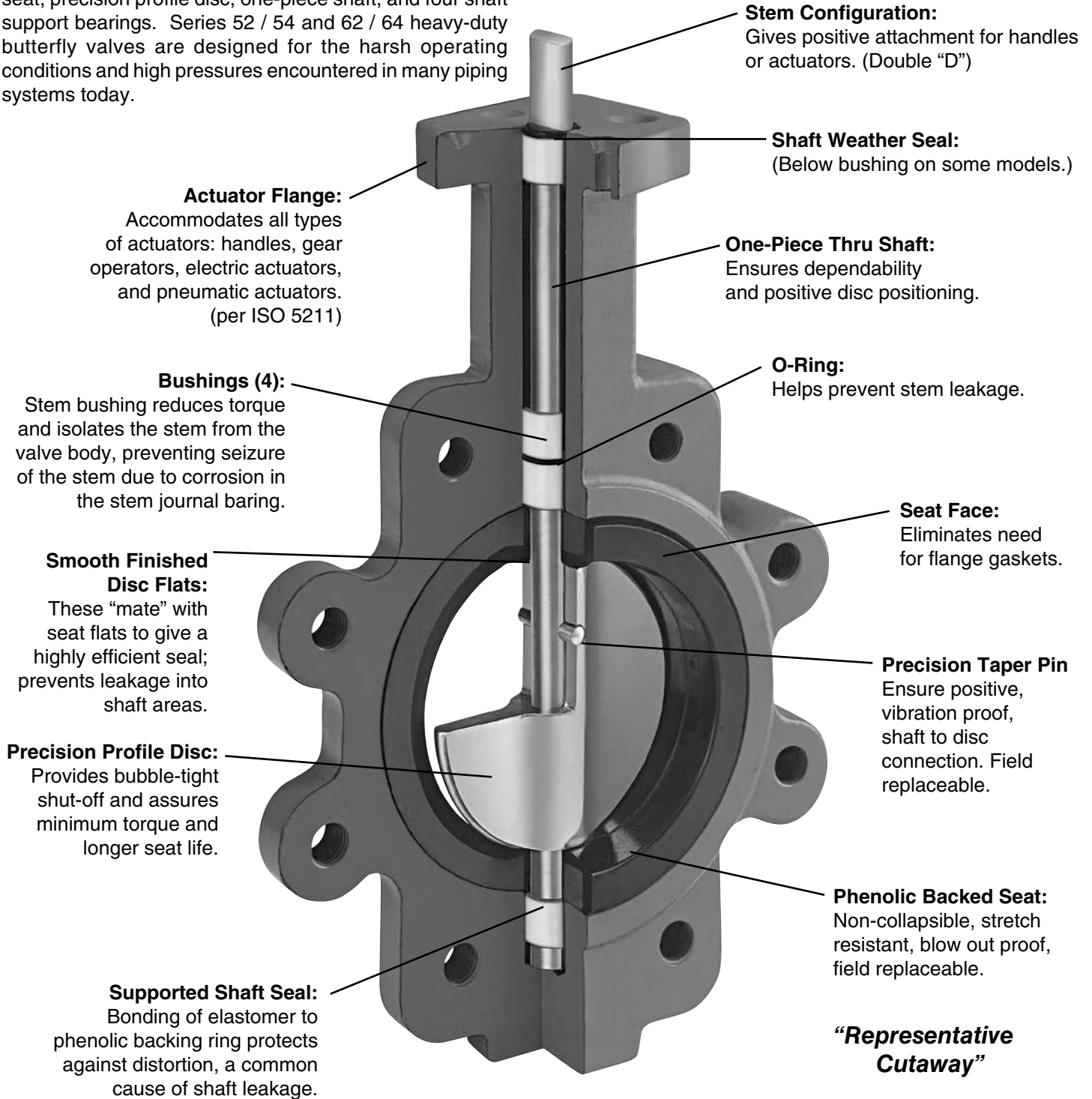

- Available in sizes 2" to 24".
- Pressure Rating: 285 psi at 100°F. Pressure/Temperature rating above 100°F corresponds to ASME B16.5 Class 150 for steel flanges.
- Available in Wafer or Lug style body.
- Wafer body features four alignment holes.
- Ideal for on-off or throttling services.
- Available with handles (2" to 6"), manual gear operators, electric actuators and pneumatic actuators (2" to 24").
- Refer to Crane automation bulletin for details of pneumatic and electric actuators.
- Compatible with ASME B16.1 Class 125 (Iron) and ASME B16.5 Class 150 (Steel) flanges or optional Class 300 (Steel)

- Bi-directional dead-end capability to 200 psi (2" to 12") and 150 psi (14" to 24") is an available option.
- Valves 14" and larger are rated at a maximum 150 psi when a companion flange is not used in dead end service.
- For bolting information, consult the Crane Butterfly Installation and Maintenance Manual.
- Vacuum Service Rating: zero leakage at 24" of mercury.
- Commercial cleaning available for non-silicone and O<sub>2</sub>.
- Type approval certification from ABS for Marine applications (2" to 24").
- PED Certification available for sizes 2" to 24".

### Valve Seating Torques (In-Lbs.)

Valve Size	Standard Disc Differential Pressure				
	50 PSI	100 PSI	150 PSI	200 PSI	285 PSI
2"	136	142	148	154	164
2 1/2"	152	160	168	176	189
3"	224	229	234	239	247
4"	380	392	404	416	436
5"	451	477	503	529	572
6"	875	946	1016	1087	1206
8"	1476	1559	1642	1726	1867
10"	2451	2613	2775	2937	3213
12"	3900	4111	4323	4534	4893
14"	5189	5467	5744	6022	6494
16"	10,985	11,569	12,154	12,738	13,732
18"	13,946	14,688	15,431	16,173	17,434
20"	14,695	15,478	16,260	17,043	18,373
24"	29,738	31,321	32,903	34,486	37,176

All torques shown on the chart were derived from test data using water at 60°F. For torques using dry gases, multiply these numbers by 2.0. For torques involving other media, please consult the factory.

There is no safety factor included in the numbers shown on this chart. For actuator sizing, Crane recommends that these values be multiplied by 1.5 for single valve applications, or 2.0 for 3-way ("tee") applications.

For PTFE seats multiply the numbers shown on this chart by 2.0.

Under certain conditions, hydrodynamic torque can meet or exceed seating and unseating torques. When designing valve systems, hydrodynamic torque must be considered to help assure correct selection for the application.

### C<sub>v</sub> Values – Valve Sizing Coefficients (US-GPM @ 1ΔP)

Size	10°	20°	30°	40°	50°	60°	70°	80°	90°
2"	0.06	3	7	15	27	44	70	105	115
2 1/2"	0.10	6	12	25	45	75	119	178	196
3"	0.20	9	18	39	70	116	183	275	302
4"	0.30	17	36	78	139	230	364	546	600
5"	0.50	29	61	133	237	392	620	930	1022
6"	0.80	34	94	153	257	422	706	1154	1320
8"	2	56	154	251	422	693	1158	1892	2165
10"	3	87	238	385	654	1073	1794	2931	3353
12"	4	153	417	681	1145	1879	3142	5132	5827
14"	6	183	500	816	1372	2252	3765	6150	7037
16"	8	271	740	1208	2031	3333	5573	9104	10,416
18"	11	318	867	1417	2382	3909	6535	10,676	12,215
20"	14	415	1133	1851	3112	5107	8538	13,948	15,959
24"	22	543	1482	2421	4069	6678	11,165	18,240	20,869

### Seat Temperature Ratings

Material	Temperature Rating °F
Buna-N	+10 to 180
EPDM (2"-16")	-30 to 275
EPDM (18"-24")	-30 to 225
Abrasive Resistant Buna-N	+10 to 180
Neoprene	+20 to 200
Hypalon	0 to 275
Viton	+10 to 275
High Temperature Viton	+10 to 400
PTFE (Series 52 / 54 & 62 / 64 only)	+40 to 250

Although elastomers have an effective operating temperature range, when used in valves, these ranges may have to be modified. The temperature ranges shown in the table have been adjusted accordingly.

**For Low Temperature:** While the seat materials selected for use in Crane butterfly valves are capable of withstanding lower temperatures without damage, the durometer of the elastomer is changed. This "hardening" of the seat may increase the operating torque beyond the structural limits of the stem and/or the disc to stem configuration.

**For High Temperature:** When using High Temperature Viton, the operating pressure of the valve is reduced above 275°F.

**Field Replacement:** Replacing seats in sizes 12" - 20" is difficult and requires factory service. Sizes 24" and above cannot be field replaced.



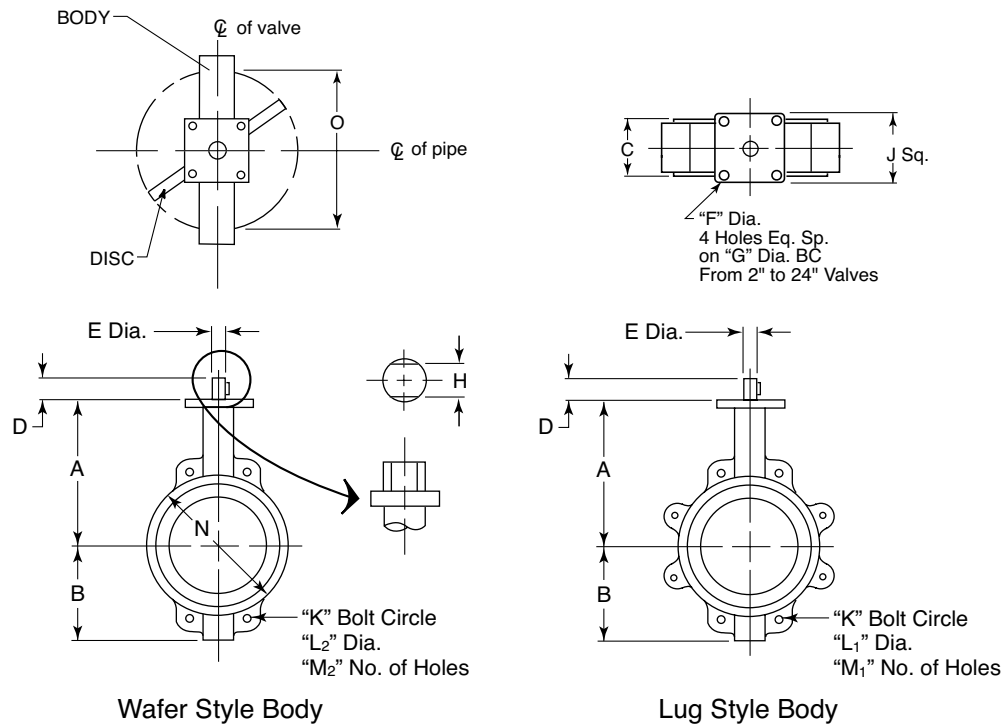

## Dimensions and Weights

For installation and maintenance instructions, please refer to the IOM manual available at [www.cranevalve.com](http://www.cranevalve.com)

Valve Size		A	B	C	D	E	F	G	H	J	K	L <sub>1</sub>	L <sub>2</sub>	M <sub>1</sub>	M <sub>2</sub>	WAFER	LUG	O
2"	in.	6 3/8	3 1/4	1 3/4	1 1/4	1 1/2	3/8	2.76	0.39	2 3/4	4 3/4	5/8-11	1 1/16	4	4	6 lbs.	9 lbs.	1.26
50	mm	161.93	82.55	44.45	31.75	12.70	9.53	70	10	69.85	120.65		17.46			2.72 kg	4.08 kg	32.0
2 1/2"	in.	6 7/8	3 3/4	1 7/8	1 1/4	1 1/2	3/8	2.76	0.39	2 3/4	5 1/2	5/8-11	1 1/16	4	4	7 lbs.	13 lbs.	1.83
65	mm	174.63	95.25	47.63	31.75	12.70	9.53	70	10	69.85	139.70		17.46			3.18 kg	5.90 kg	46.5
3"	in.	7 1/8	4	1 7/8	1 1/4	1 1/2	3/8	2.76	0.39	2 3/4	6	5/8-11	1 1/16	4	4	10 lbs.	14 lbs.	2.54
80	mm	180.98	101.60	47.63	31.75	12.70	9.53	70	10	69.85	152.40		17.46			4.54 kg	6.35 kg	64.5
4"	in.	7 7/8	4 7/8	2 1/4	1 1/4	1 1/2	3/8	2.76	0.47	2 3/4	7 1/2	5/8-11	1 1/16	8	4	13 lbs.	19 lbs.	3.54
100	mm	200.03	123.83	53.98	31.75	15.88	9.53	70	12	69.85	190.50		17.46			5.90 kg	8.62 kg	89.9
5"	in.	8 3/8	5 3/8	2 1/4	1 1/4	1 1/2	3/8	2.76	0.55	2 3/4	8 1/2	3/4-10	1 1/16	8	4	18 lbs.	22 lbs.	4.36
125	mm	212.73	136.53	57.15	31.75	19.05	9.53	70	14	69.85	215.90		20.64			8.16 kg	9.98 kg	110.7
6"	in.	8 7/8	5 7/8	2 1/4	1 1/4	1 1/2	3/8	2.76	0.55	2 3/4	9 1/2	3/4-10	1 1/16	8	4	21 lbs.	31 lbs.	5.74
150	mm	225.43	149.23	57.15	31.75	19.05	9.53	70	17	69.85	241.30		20.64			9.53 kg	14.06 kg	145.8
8"	in.	10 1/4	7 3/4	2 1/2	1 3/4	1 1/2	7/16	4.02	0.67	3 3/4	11 3/4	3/4-10	1 1/16	8	4	34 lbs.	49 lbs.	7.63
200	mm	260.35	196.85	63.50	44.45	22.23	11.11	102	17	95.33	298.45		20.64			15.42 kg	22.23 kg	193.8
10"	in.	11 1/2	8 1/4	2 3/4	1 3/4	1 1/2	7/16	4.02	0.87	3 3/4	14 3/4	7/8-9	1 1/16	12	4	45 lbs.	62 lbs.	9.54
250	mm	292.10	209.55	69.85	44.45	28.58	11.11	102	22	95.33	361.95		23.81			20.41 kg	28.12 kg	242.3
12"	in.	13 1/4	9 3/4	3 1/8	1 3/4	1 1/2	7/16	4.02	0.95	3 3/4	17	7/8-9	1 1/16	12	4	74 lbs.	105 lbs.	11.5
300	mm	336.55	247.65	79.38	44.45	31.75	11.11	102	24	95.33	431.80		23.81			33.57 kg	47.63 kg	292.1
14"	in.	14 1/2	11	3 1/8	1 3/4	1 1/2	7/16	4.02	0.95	3 3/4	18 3/4	1-8	1 1/16	12	4	109 lbs.	178 lbs.	12.81
350	mm	368.30	279.40	79.38	44.45	31.75	11.11	102	24	95.33	476.25		26.99			49.44 kg	80.74 kg	325.4
16"	in.	15 3/4	12	3 1/2	2	1 5/8	7/16	6.50	1.06	6 1/2	21 1/4	1-8	1 1/16	16	4	135 lbs.	224 lbs.	15
400	mm	400.05	304.80	88.90	50.80	33.34	22.23	165	27	165.10	539.75		26.99			61.24 kg	101.60 kg	381.0
18"	in.	16 3/8	15	4 1/8	2	1 5/8	7/16	6.50	1.26	6 1/2	22 3/4	1 1/8-7	1 1/16	16	4	190 lbs.	265 lbs.	16.87
450	mm	422.28	381.00	107.95	50.80	41.28	22.23	165	32	165.10	577.85		30.16			86.18 kg	120.20 kg	428.5
20"	in.	18 7/8	15	5 1/4	2 1/2	1 5/8	7/16	6.50	1.26	6 1/2	25	1 1/8-7	1 1/16	20	4	316 lbs.	455 lbs.	18.69
500	mm	479.43	381.00	133.35	63.50	41.28	22.23	165	32	165.10	635.00		25.00			143.34 kg	206.38 kg	474.7
24"	in.	22 1/8	18	6 1/8	2 3/4	3	7/16	6.50	2.36	6 1/2	29 1/2	1 1/8-7	1 1/16	20	4	506 lbs.	702 lbs.	22.57
600	mm	561.98	457.20	155.58	69.85	76.20	22.23	165	60	165.10	749.30		28.18			229.52 kg	318.42 kg	573.3

NOTE: 20" Wafer: L<sub>2</sub> dia. Hole is Tapped w/1-1/8-7 on Each Side

24" Wafer: L<sub>2</sub> dia. Hole is Tapped w/1-1/4-7 on Each Side

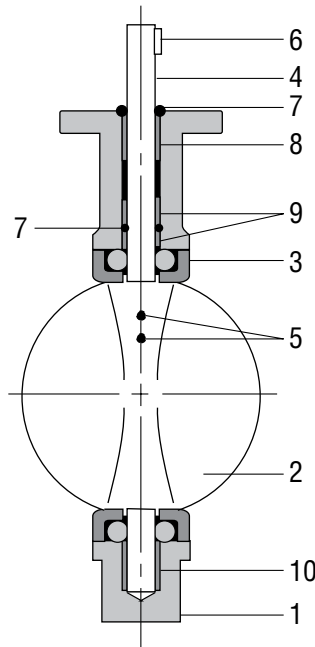

**Bill of Materials (52 / 54 & 62 / 64)**

Item	Description	Materials	Optional Materials
1	Body	Carbon Steel A216 GR.WCB	316SS A351 GR.CF8M Carbon Steel A-216 GR.WCB Impact Tested*
2	Disc	316 Stainless	Aluminum Bronze, Monel
3	Seat	Buna-N or EPDM	Neoprene, Hypalon, Abrasion Resistant Buna-N, Low Temperature Viton, High Temperature Viton, PTFE
4	Shaft	316 Stainless Steel	17-4 PH, Monel
5	Taper Pin	300 Series Stainless	Monel
6	Key	Carbon Steel	No Option Available
7	O-Ring	Buna-N	No Option Available
8, 9, 10	Bushing	PTFE	No Option Available

\* Crane Series 52/54 Carbon Steel valves with CE marking are good to 0°F for non-impact tested bodies and -20°F for impact tested carbon steel bodies. Please consult factory for the correct ordering code.

Handles are available for on/off and throttling control of Crane resilient seated butterfly valves. These handles can be used for manual actuation of 2" to 12" valves at 200 psi and for 2" to 6" valves at 285 psi. For valves larger than 8", excessive operator effort and extreme handle reaction to internal valve forces are possible. In these cases, a gear operator is recommended for safe operation.

## Features

The rugged construction of Crane handles makes them ideally suited for manually actuating smaller valves. The latchplate permits the valve to be locked in any of the 10 positions on DIT handles or in any position on IOL handles.

## Specifications

- DIT Mechanically locks the valve in any of the 10 positions from 0° to 90° in 10° increments
- DIT/IOL Can hold the valve in intermediate positions (32°, 68°, etc.) and can also be locked in 0° and 90° positions

## Dimensions and Weights

Valve Size		A	B	Weight	
				DIT	DIT/IOL
2-6	in.	2.25	10.5	1.8	2.0
50-150	mm	57.15	266.7	0.8	0.9
8-12	in.	3.34	14.0	4.0	-
200-300	mm	84.84	355.6	1.8	-

Plates are adaptable for ISO or standard mounting flange.

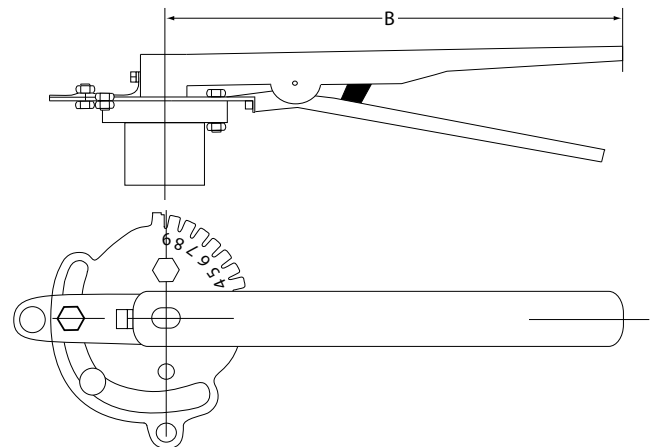
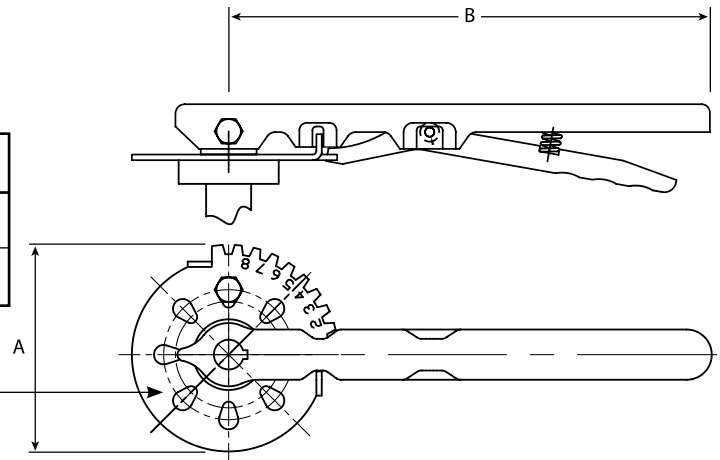

Gear operators can be used for on/off and throttling control of Crane resilient seated butterfly valves. All models are weatherproof and usable for above ground or buried service. For manual operation of valves, gear operators are required for valves 14" and larger and are recommended for valves 8" and larger.

## Features

Gear operators from Crane are 90° manual actuators, and they come with a handwheel, chainwheel, or square nut input device. The durable housing completely encloses the worm gear (on the input shaft) and the segment gear (on the output). Adjustable stops are standard and factory set when installed at the factory. Fully adjustable memory stops are available as an option. A position indicator is standard on all models for above ground service. An optional version is available for buried service applications. Contact customer service for more information.

## Specifications

**Operation** Handwheel or chainwheel (12" standard, others available) or 2" square nut. Input shaft extension available.

**Mounting** Available with bolt patterns and bore/keyway for direct mount to all 2" through 30" Crane resilient seated butterfly valves. Gears are drilled for ISO pattern through 24". Contact factory for 30" and above.



## Dimensions and Weights

Valve Size		Oper.	A	A1	C	E	F	G	H	Ø1	J	ØK	M	D	P	Q	Ø	ØD2	Ø3	Wt. (Kg.)
2-6	in.	XJ30	12.56	9.52	10.72	2.52	14.80	2.36	6.00	0.76	1.36	0.24	1.66	3.68	3.36	7.06	12.00	6.08	1.52	27.1
50-150	mm		314.00	238.00	268.00	63.00	37.00	59.00	150.00	19.00	34.00	6.00	41.50	92.00	84.00	176.50	300.00	152.00	38.00	(12.3)
8-14	in.	XJ50	12.28	9.04	10.60	3.12	1.54	2.74	5.12	0.76	1.36	0.24	1.53	5.60	3.36	7.90	12.00	6.48	1.52	31.7
200-350	mm		307.00	226.00	265.00	78.00	38.50	68.50	128.00	19.00	34.00	6.00	38.20	140.00	84.00	197.50	300.00	162.00	38.00	(14.4)
16-18	in.	XJ80	16.28	11.08	13.76	4.80	1.60	4.08	5.60	1.00	1.36	0.32	2.28	7.88	5.00	11.60	18.00	10.40	2.00	77.4
400-450	mm		407.00	277.00	344.00	120.00	40.00	102.00	140.00	25.00	34.00	8.00	57.00	197.00	125.00	290.00	450.00	260.00	50.00	(35.2)
Valve Size		Oper.	A	B	C	D	E	F	Ø	Ø1	Ø2	Wt. (Kg.)								
20	in.	XJ300	7.40	6.40	4.40	18.90	4.60	2.50	18.00	0.98	0.32	121.0								
500	mm		185.00	160.00	110.00	473.00	115.00	63.00	450.00	25.00	8.00	(55.0)								
24	in.	XJ300	7.40	6.40	5.00	20.00	4.80	2.50	18.00	0.98	0.32	132.0								
600	mm		185.00	160.00	125.00	500.00	120.00	63.00	450.00	25.00	8.00	(60.0)								
30	in.	DG 50	10.60	6.60	6.40	21.80	5.12	3.12	18.00	0.98	0.32	198.0								
750	mm	202	265.00	165.00	160.00	545.00	128.00	78.00	450.00	25.00	8.00	(90.0)								
36	in.	DG 160	11.12	8.04	7.84	21.44	10.32	5.04	17.40	0.98	0.32	424.6								
900	mm	466	278.00	201.00	196.00	611.00	258.00	126.00	435.00	25.00	8.00	(193.0)								
42	in.	DG 160	16.72	10.20	9.60	25.56	12.40	5.04	17.40	0.98	0.32	792.0								
1050	mm	466	418.00	255.00	240.00	611.00	310.00	126.00	435.00	25.00	8.00	(360.0)								
48	in.	DG 160	16.72	10.20	9.60	25.56	12.40	5.04	17.40	0.98	0.32	792.0								
1200	mm	466	418.00	255.00	240.00	639.00	310.00	126.00	435.00	25.00	8.00	(360.0)								

Some sizes require different operators, please consult factory.

**PNEUMATIC – DOUBLE ACTING****Standard Features:**

Torque Range – 30 in-lbs to 107,531 in-lbs  
 Housing – Anodized aluminum  
 Mounting – DIN ISO 5211, direct mounting to Crane valves  
 Position Indicator – NAMUR standard  
 Operating Pressure – 40 to 120 PSIG  
 Temperature Range – -4°F (-20°C) to 176°F (80°C)  
 Size Range – 14 models to choose from  
 Adjustable Travel Stops – Both directions  
 Accessory Interfaces – VDI/VDE 3845 (NAMUR) standard

**Optional Features:**

Temperature Range – 4°F to 250°F, -40°F to 175°F  
 Solenoid Valves – 3 or 4 way  
 Limit Switches – Adjustable cam operated  
 Positioners – Pneumatic or Electro-pneumatic  
 DC-1 Dribble Control – Two-stage shutoff  
 180° Actuation – 2 or 3 position  
 Manual Override – De-clutchable gear type  
 Speed Controls – Adjust cycle time  
 Special Applications – Offshore, nuclear, hygienic, and gas or oil operation

**PNEUMATIC – SPRING RETURN****Standard Features:**

Torque Range – 42 in-lbs to 77,211 in-lbs  
 Housing – Anodized aluminum  
 Mounting – DIN ISO 5211, direct mounting to Crane valves  
 Position Indicator – NAMUR standard  
 Operating Pressure – 40 to 120 PSIG  
 Temperature Range – -4°F (-20°C) to 176°F (80°C)  
 Size Range – 14 models to choose from  
 Adjustable Travel Stops – Both directions  
 Accessory Interfaces – VDI/VDE 3845 (NAMUR) standard

**Optional Features:**

Temperature Range – 4°F to 250°F, -40°F to 175°F  
 Solenoid Valves – 3 or 4 way  
 Limit Switches – Adjustable cam operated  
 Positioners – Pneumatic or Electro-pneumatic  
 DC-1 Dribble Control – Two-stage shutoff  
 180° Actuation – 2 or 3 position  
 Manual Override – De-clutchable gear type  
 Speed Controls – Adjust cycle time  
 Special Applications – Offshore, nuclear, hygienic, and gas or oil operation



## VANE

### Standard Features:

- Double acting and fail safe versions available
- Housing – Die-cast aluminum
- Operating Pressure – 40 to 120 PSIG
- Temperature Range – 0°F to 225°F
- Powerful actuation in a compact and lightweight package
- Only one moving part
- Dual external travel stops allow rotation adjustment of up to  $\pm 10^\circ$  at each end of the stroke
- Fail safe models use a pneumatic accumulator to assure valve closure upon loss of supply pressure
- Stacking two vane actuators enables 180° movement (2 or 3 position)

### Optional Features:

- Limit switch
- Locking device
- Breather block
- Dribble control
- Sandwich de-clutchable manual gear override
- Solenoid valve
- Positioners
- PTFE interior coatings
- High or low temperature trim

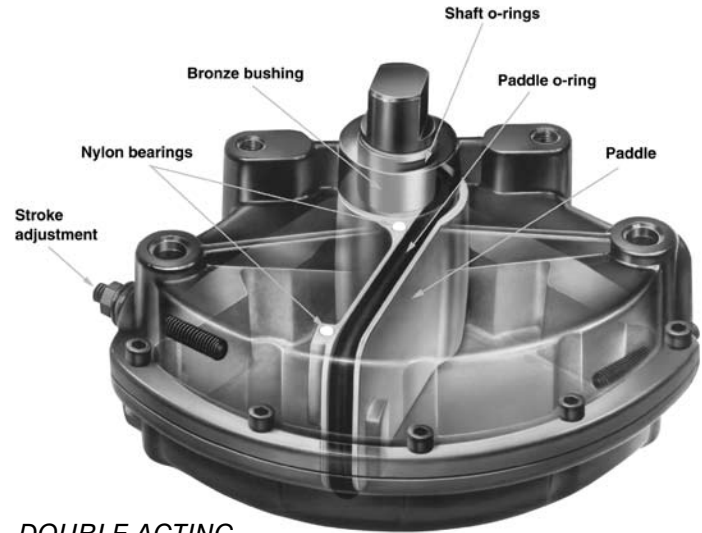

*DOUBLE ACTING*



*FAIL SAFE*

The nomograph on the following page gives the relationships of valve size, flow, velocity, and pressure drop for various disc positions.

### Sample Calculation, Liquid (see dark blue line on chart)

**Given:**

Water (1.0 specific gravity) at 60°F is flowing through a 6-inch valve at a rate of 1000 gpm.

**Find:**

Line velocity (ft./sec.) and pressure drop when valve is in full-open (disc at 90°) position.

**Solution:**

From the 6-inch valve size at lower left of nomograph, go diagonally up to the intersecting horizontal line for 1000 gpm. From that point, proceed directly down to determine line velocity as 11 ft./sec.

For pressure drop, return to the 1000 gpm intersection and continue up vertically to “90° disc open” intersecting diagonal line. From this point, go horizontally to the left to determine pressure drop as 0.5 psi.

### Sample Calculation, Gas (see light blue line on chart)

**Given:**

Gas (0.8 lb/cu. ft. density) is flowing through an 8-inch valve at a rate of 1500 cu. ft./min.

**Find:**

Line velocity (ft./min.) and pressure drop when valve is in full-open (disc at 90°) position.

**Solution:**

From 8-inch valve size at lower left of nomograph, go diagonally up to the intersecting horizontal line for 1500 cu. ft./min. From that point, proceed directly down to the bottom line of the nomograph to determine line velocity as 4000 ft./min.

For pressure drop, return to the 1500 cu. ft./min. intersection and continue up vertically to “90° disc open” intersecting diagonal line. From this point, go horizontally to the left to determine pressure drop as 17 psi. Now, convert pressure drop to gas by dividing gas density by liquid density and multiplying by 17.

$$\frac{0.8}{62.34} \times 17.0 = 0.22 \text{ psi}$$

### General Notes

- Liquid flow data is based on pressure drop and flow rate with viscosity similar to water at 60° F using flow coefficient.
- Velocities for liquids with densities similar to water should be less than 16 ft./sec.
- Nomograph flow rate for gases is in cubic feet per minute (CFM) at flowing conditions. To convert flow rate from standard cubic feet per minute to CFM, use the following formula:  

$$\text{CFM} = \frac{(\text{SCFM} \times 14.7) \times (460 + ^\circ\text{F})}{(\text{line pressure, psia}) \times 520}$$
- Gas density in lbs./cu. ft. equals:

$$\left( \frac{270 \times}{\text{line pressure, psia}} \right) \times \left( \frac{\text{specific gravity of gas (relative to air)}}{460 + ^\circ\text{F}} \right)$$

Size	Cv at Full-Open
2"	115
2 1/2"	196
3"	302
4"	600
5"	1022
6"	1579
8"	3136
10"	5340
12"	8250
14"	11917
16"	16388
18"	21705
20"	27908
24"	43116
30"	73426

### Definitions

**C<sub>v</sub>** = Flow coefficient for valves; expresses flow rate in gallons per minute of 60°F water with 1.0 psi pressure drop across valve.

$$C_v = Q \sqrt{\frac{P}{62.4 \Delta P}}$$

**K** = resistance coefficient.

$$K = d \sqrt{\frac{29.9}{C_v}}$$

**P** = weight density of fluid, in pounds per cubic foot.

**d** = internal diameter of Schedule 40 pipe, in inches.

**Q** = rate of flow, in gallons per minute.

**ΔP** = differential pressure, in pounds per square inch gauge.

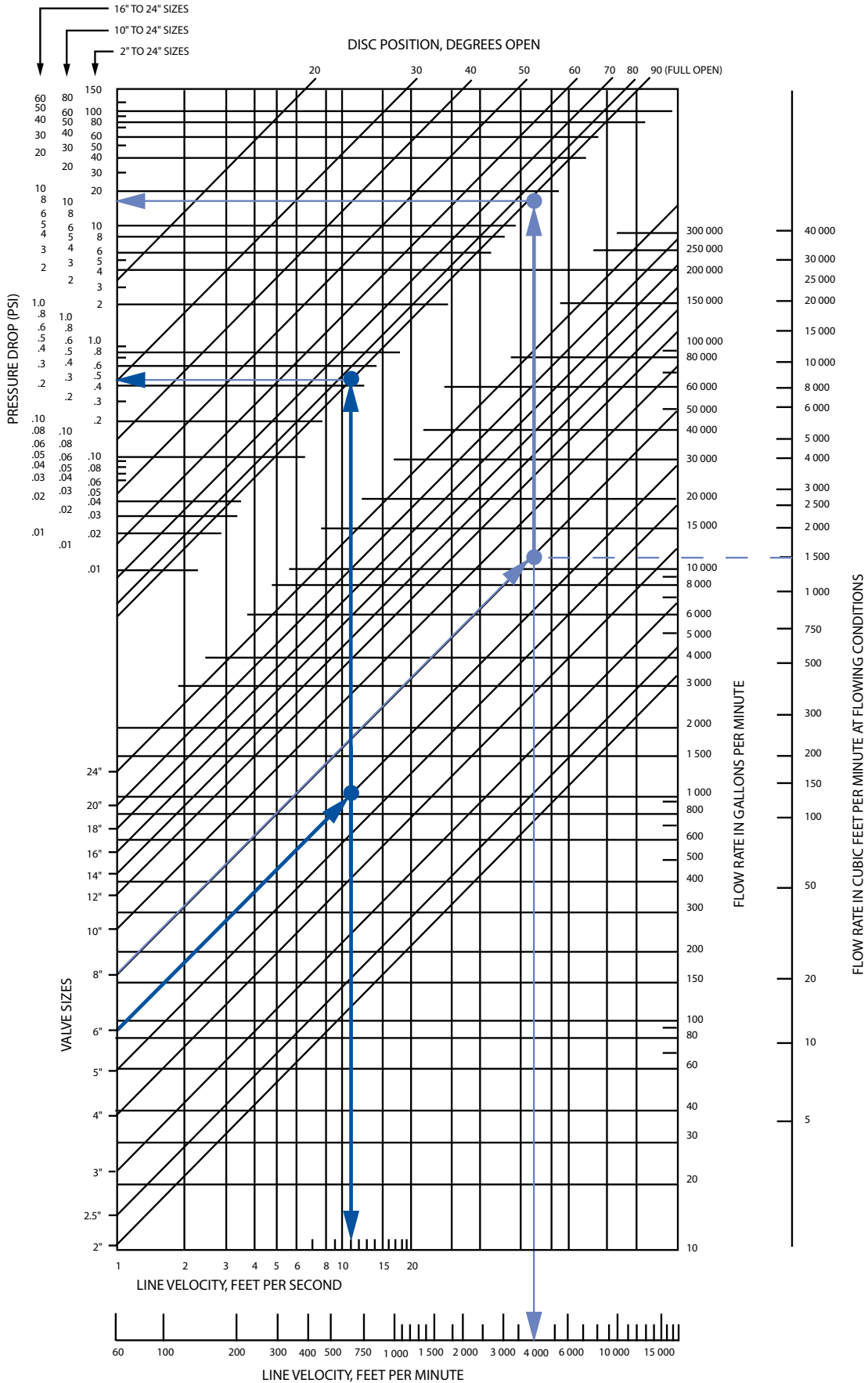



# Crane Butterfly Valves

## Global Headquarters

9200 New Trails Drive, Suite 200  
The Woodlands, Texas 77381-5219  
Tel: 281-298-5463  
Fax: 281-292-1749

## Conroe, TX Operations

9860 Johnson Road  
Montgomery, TX 77316  
Tel: 936-588-8380  
Fax: 936-588-8381

## Cullman, AL Operations

2129 3rd Avenue  
Cullman, AL 35055  
Tel: 800-786-2542  
Fax: 256-775-3860

## Crane Supply Executive Office

615 Dixon Road  
Toronto, Ontario M9W 1H9  
Tel: 416-244-5351  
Fax: 416-244-4621  
www.cranesupply.com

## Ningjin Operations

No. 8 Youyi Street Ningjin County  
Hebei Province, China 055550  
Tel: +86-319-580-6651  
Fax: +86-319-580-8661

[www.cranevalve.com](http://www.cranevalve.com)

## Crane Valves North America

Thinking Globally

### CENTER LINE®

Resilient Seated Butterfly and Check Valves  
Pneumatic and Electric Actuators

### CRANE®

Cast Steel, Bronze, Iron and Butterfly Valves

### FLOWSEAL®

High Performance Butterfly Valves

### JENKINS®

Bronze, Iron and Cast Steel Valves

### DUO-CHEK®

High Performance Wafer Check Valves

### ALOYCO®

Corrosion Resistant Gate, Globe and Check Valves

### NOZ-CHEK®

Severe Service Check Valves

### CRANE NUCLEAR, INC.

Valves Designed for Nuclear Service  
Diagnostic Valve Repair, Equipment and Services

### PACIFIC®

High Pressure and Severe Service Valves  
Quarter Turn Severe Service Plug Valves

### CRANE® SERVICE CENTERS

Certified OEM Valve Repair Services

**CRANE**

®